

NUT INSERTED WHEEL

The cool cut for face grinding

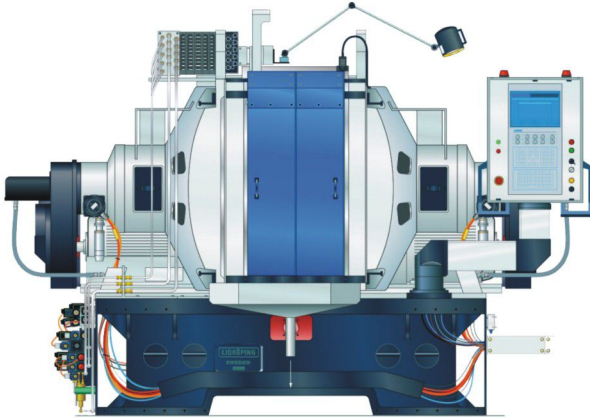

- ▶ Sterling offers specially designed disc grinding wheels with special bond system, which is the best in India.
- ▶ Suitable for machines like Gardner, Bessley, Diskus, Foldage, Nippie, Modular, Parivartan, OMD, Bennet, Rollund etc.

International Range

FEATURES

- Revolutionary, sharp, durable, engineered abrasive grains

BENEFITS

- Versatile, for all low medium and high force applications ranging from cast iron to stainless steel and hard to grind materials.
- 30% higher metal removal rate.
- 15% lower threshold power.
- Highest productivity, lowest total grinding cost.

Premium Range

FEATURES

- High-performance engineered abrasive grain optimally spaced.
- High porosity.

BENEFITS

- High metal removal rates, able to grind large areas of contact.
- Exceptional part integrity and quality, superior surface finish.
- Long wheel life, dramatically shorter grinding cycle.

Application

International Range

Premium Range

Professional Range

Bearing Industries

Bearing Ring	3CG80 J8 BS	73A80 J8 BS	A OR AA80 J8 BS
Bearing Roller	73A60 J5 BS	A A60 J5 BS	A60 J5 BS

Automotive Industries

Connecting Rod	3CG60 K5 BS	73A60 L5 BS	AA60 K5 BS
Piston Ring	1CG/GC K8 BS	GC60 K8 BS	C60 K8 BS
Spring	3CG24 P7 BS	FSP24 P7 BS	A24 P7 BS
Sintered Component		GC60 K5 BS	C60 K5 BS
Valve Plate		75A46 N5 BS	AA54 N5 BS
Washer		75A60 J8 BS	DA60 N4 BSM



STERLING ABRASIVES LTD.